

The **Fozmula** fuel sender is a simple low cost fuel tank level sender designed to drive any gauge requiring a 10 - 180Ω input match.

Adjustable to fit tanks between 6" (150mm) and 24" deep (610mm), the sender is rugged enough to be used in agriculture, construction, forestry and most off highway vehicles.



### Specification

#### Fluid Types:

Fluids compatible with the construction materials

#### Dimensions:

See below

#### Electrical:

Gauge match: 10 - 180Ω. Others available on request

#### Construction:

Flange and frame: Steel zinc plated

Float: HDPE

Float arm: Steel zinc plated

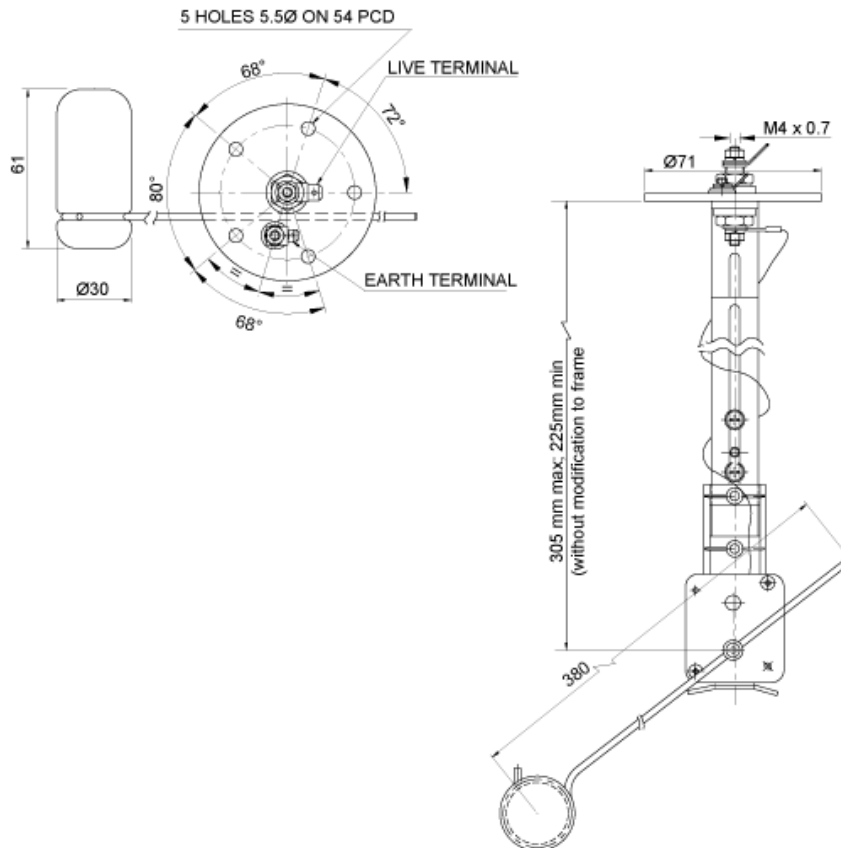

Fozmula Limited, Berrington Road, Leamington Spa, Warwickshire, CV31 1NB, UK

Tel: +44(0)1926 466700 Fax: +44(0)1926 450473 E-mail: sales@fozmula.com Website: www.fozmula.com

E. & O. E. © Fozmula Limited. December 2003 Issue No. 1

Since the suitability of these products depends upon a wide range of factors not in our control, Fozmula Limited expects and understands that you will conduct the testing and evaluation necessary to determine that these products are suitable for your application. Whilst every effort is made to ensure the above details are correct at the time of printing, Fozmula Limited reserves the right to make material changes, and or technical changes without notification.